

MIL-DTL-38999 Series I & II

MS3186	A	113	W	C
SERIES	Material	DASH #	FINISH	See note 2
			A: Hard Anodized Black N: Electroless Nickel W: Cadmium Olive Drab	

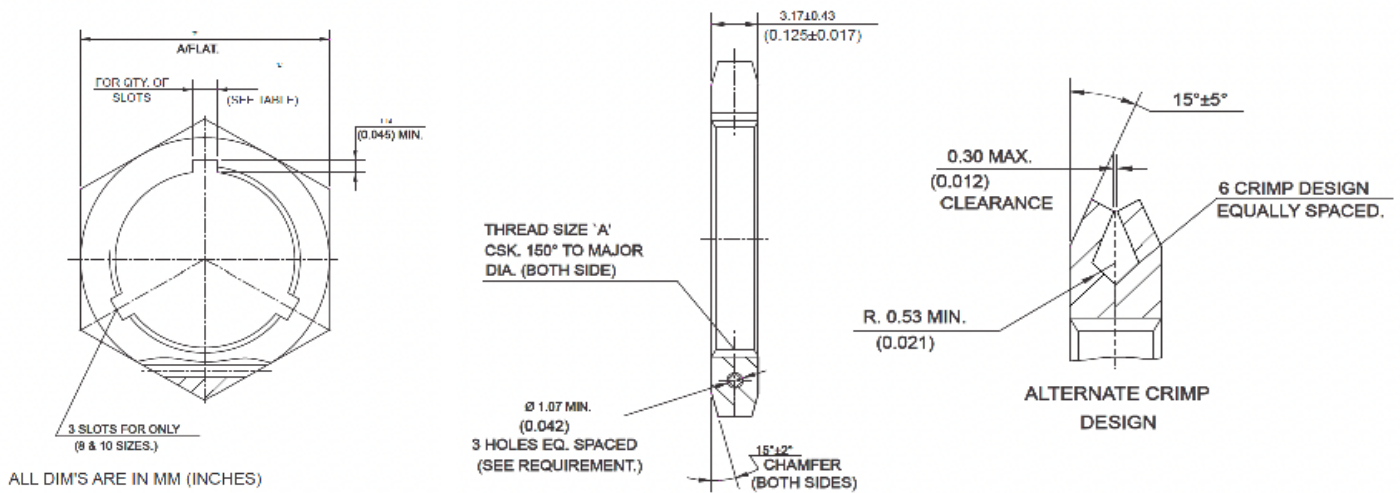

TABLE A

Dash #	MIL-DTL-26482	MIL-DTL-38999 Ser-I	MIL-DTL-26482 Ser-II	'A' Thread Size. -2B	'E' MAX.		'P' ±0.43 ±(0.017)		'S' MIN. NO. OF SLOTS
					mm	inch	mm	inch	
102	08	--	--	0.5625-24UNEF	3.43	0.135	19.05	0.750	3
106	10	09	--	0.6875-24UNEF			22.22	0.750	
108	--	11	--	0.8125-20UNEF			25.40	1.000	
109	12	--	08	0.875-20UNEF			26.97	1.062	1
111	14	13	10	1.000-20UNEF			30.17	1.188	
113	16	15	12	1.125-18UNEF			33.32	1.312	
116	18	17	14	1.250-18UNEF			36.52	1.438	
117	20	19	16	1.375-18UNEF	39.67	1.562			
120	22	21	18	1.500-18UNEF	42.87	1.688			
121	24	23	20	1.625-18UNEF	46.02	1.812			
122	--	25	22	1.750-18UNEF	50.80	2.000	1		
123	--	--	24	1.875-16UN	53.95	2.125			