

## 90°; SELF-LOCK/SPIN

Connector Group K

MIL-DTL-38999 Series I & II

M85049	/47	S	W	10
SERIES	SLASH #	COUPLING	MATERIAL/FINISH	DASH #
	47: 90°	S: Self Lock Omit for Spin	N: Aluminum Alloy/Electroless Nickel W: Aluminum Alloy/Cadmium S: Stainless Steel/Passivate	Table A

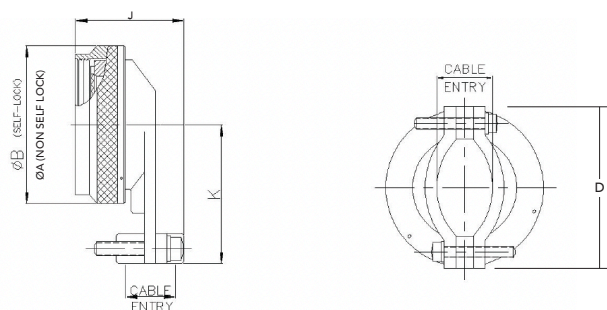

TABLE A

DASH #	Connector Shell Size	A Ø Max.		B Max.		D Max.		J. Max.		K. Max		Cable Entry			
												Min.		Max.	
		inch	mm	inch	mm	inch	mm	inch	mm	inch	mm	inch	mm	inch	mm
8	8 / 9	0.75	19.05	0.86	21.82	0.85	21.59	1.38	35.05	1.00	25.40	0.10	2.49	0.23	5.94
10	10 / 11	0.85	21.59	0.98	24.99	0.90	22.86	1.38	35.05	1.10	27.94	0.15	3.89	0.23	5.94
12	12 / 13	1.00	25.40	1.16	29.36	1.10	27.94	1.46	37.8	1.10	27.94	0.19	4.83	0.33	8.33
14	14 / 15	1.10	27.94	1.28	32.54	1.15	29.21	1.63	41.40	1.25	31.75	0.26	6.60	0.46	11.61
16	16 / 17	1.25	31.75	1.41	35.71	1.30	33.02	1.80	45.72	1.30	33.02	0.28	7.19	0.61	15.60
18	18 / 19	1.40	35.56	1.52	38.51	1.50	38.10	1.82	46.23	1.35	34.29	0.33	8.26	0.63	16.10
20	20 / 21	1.50	38.10	1.64	41.68	1.60	40.64	1.90	48.26	1.60	40.64	0.34	8.71	0.70	17.73
22	22 / 23	1.65	41.91	1.77	44.86	1.70	43.18	2.04	51.82	1.75	44.45	0.38	9.68	0.82	20.90
24	24 / 25	1.75	44.45	1.89	48.03	1.80	45.72	2.15	54.61	1.85	46.99	0.42	10.62	0.85	21.67