

90°; SELF-LOCK/SPIN

Connector Group K

MIL-DTL-38999 Series I & II

M85049	/123	-	10	W
SERIES	SLASH #	COUPLING	DASH #	FINISH
	123: 90°	S: Self Lock -: Spin	Table A	A: Hard Anodized Black N: Electroless Nickel W: Cadmium Olive Drab Z: Black Zinc Nickel

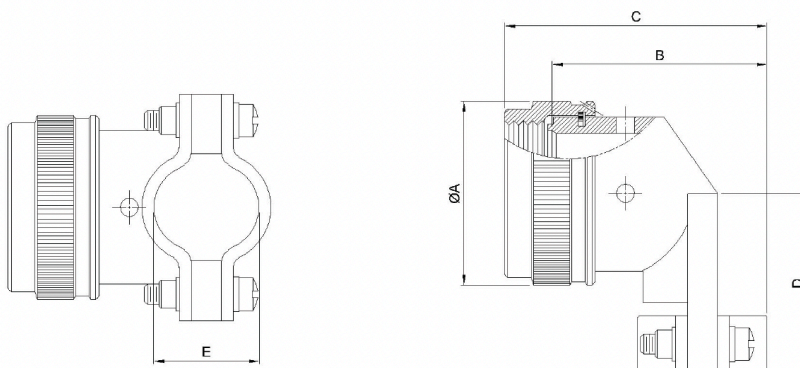

DASH #	A Ø Max.		B Max.		C Max.		D Max.		E Closed	
	inch	mm	inch	mm	inch	mm	inch	mm	±.031 inch	±.787 mm
08	0.86	21.79	0.86	21.84	1.10	27.94	0.81	20.57	0.22	5.56
10	0.98	24.99	0.94	23.88	1.18	29.97	0.87	22.10	0.26	6.71
12	1.16	29.39	1.14	28.96	1.38	35.05	0.93	23.62	0.34	8.74
14	1.28	32.49	1.20	30.48	1.44	36.58	0.99	25.15	0.46	11.68
16	1.41	35.71	1.34	34.04	1.58	40.13	1.06	26.92	0.55	13.84
18	1.52	38.51	1.46	37.08	1.70	43.18	1.23	31.24	0.62	15.62
20	1.64	41.71	1.58	40.13	1.82	46.23	1.30	33.02	0.70	17.73
22	1.77	44.91	1.71	43.43	1.95	49.53	1.36	34.54	0.78	19.81
24	1.87	47.47	1.83	46.48	2.07	52.58	1.42	36.07	0.85	21.59