

STRAIGHT; SELF-LOCK/SPIN

Connector Group J

MIL-DTL-26482 Series II; MIL-DTL-83723 Series III; AS50151; AS81703

M85049	/120	-	10	W
SERIES	SLASH #	COUPLING	DASH #	FINISH
	120: 90°	S: Self Lock -: Spin	Table A	A: Hard Anodized Black N: Electroless Nickel W: Cadmium Olive Drab Z: Black Zinc Nickel

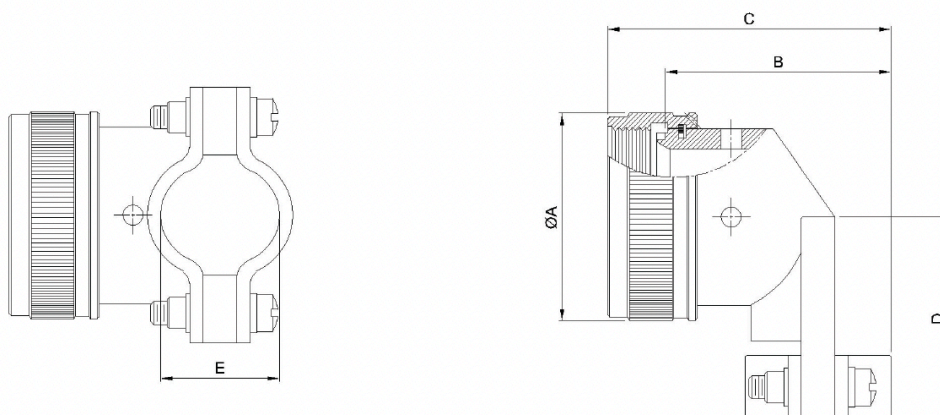

TABLE A

DASH #	Shell Size Code	A Ø Max.		B Max.		C Max.		D Max.		E Closed	
		inch	mm	inch	mm	inch	mm	inch	mm	±.031	±.787
8	8S	0.88	22.35	0.93	23.62	1.29	32.77	0.81	20.57	0.22	5.56
10	10S, 10SL	0.94	23.88	1.02	25.91	1.38	35.05	0.87	22.10	0.26	6.71
12	12, 12S	1.12	28.45	1.21	30.73	1.57	39.88	0.93	23.62	0.34	8.74
14	14, 14S	1.19	30.23	1.27	32.26	1.63	41.40	1.00	25.40	0.46	11.68
16	16, 16S	1.44	36.58	1.42	36.07	1.78	45.21	1.06	26.92	0.55	13.84
18	18	1.56	39.62	1.53	38.86	1.89	48.01	1.23	31.24	0.62	15.62
20	20	1.69	42.93	1.65	41.91	2.01	51.05	1.30	33.02	0.70	17.73
22	22	1.75	44.45	1.78	45.21	2.14	54.36	1.36	34.54	0.78	19.81
24	24	1.88	47.75	1.90	48.26	2.26	57.40	1.42	36.07	0.85	21.59
28	28	2.12	53.85	2.20	55.88	2.72	69.9	1.63	41.40	0.95	24.13
32	32	2.50	63.50	2.27	57.66	2.79	70.87	1.86	47.24	1.02	25.78