



ALUMALIGHT

Ideal Where Lightweight Connector Support Is Needed

- Commercial lightweight metal backshells
- Comparable in weight, performance & price to composite
- Meets or exceeds MIL AS85049 standard functionality
- Available in the following backshell families
 - Environmental
 - EMI/RFI Strain Relief
 - EMI/RFI Band Lock

	Metal	Composites	AlumaLight
Mil-Standards & Performance	X	X	X
Strength & Durability	X		X
Reliability	X		X
Lightweight		X	X
EMI Shielding	X		X
Environmental	X		X
Strain Relief	X	X	X

Environmental

BEL1	S	S	L	10	03	3	C	W
BASIC PART #	ANGLE	COUPLING	CONNECTOR GROUP	SHELL SIZE	ENTRY SIZE	STANDARD LENGTH & FIGURE	C: Clamp N:Nut	MATERIAL & FINISH
	S: Straight	S:Self Lock	K: MIL-DTL-38999 Series I & II L: MIL-DTL-38999 Series III & IV	Table A	Table A			Table B

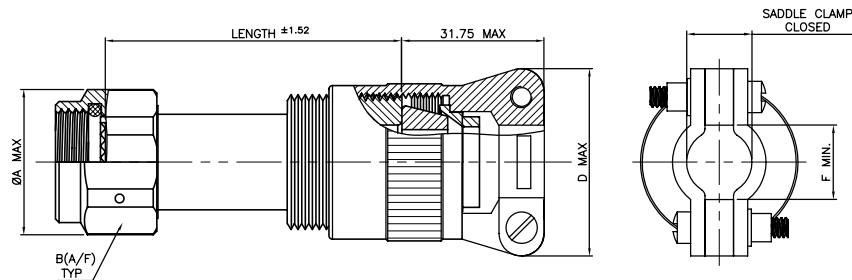

Shell Size	Length Code	ØA MAX.	B HEX	MAX. Entry Size
8	1	20.40	16.99/17.42	02
	2			
10	1	21.79	18.69/19.05	03
	2			
12	1	24.99	21.84/22.23	04
	2			
14	1	29.39	24.89/25.40	05
	2			
	3			
16	1	32.51	28.58/27.94	06
	2			
	3			
18	1	35.71	31.09/31.75	07
	2			
	3			
20	1	38.51	34.24/34.93	07
	2			
	3			
22	1	41.51	37.31/38.20	08
	2			
	3			
24	1	44.91	40.16/41.28	10
	2			
	3			

Entry Size	Cable Range		Saddle Clamp Closed ± 0.78	D MAX.	F MIN.
	Inch	mm			
02	3.18	6.35	6.70	23.90	6.90
03	6.35	9.53	8.70	28.40	9.53
04	7.92	12.70	11.70	30.20	12.70
05	11.1	15.88	15.70	39.60	15.88
06	14.27	19.05	17.70	42.90	19.05
07	17.45	22.23	19.80	44.50	22.23
08	20.62	25.40	21.60	47.80	25.40
09	23.80	28.58	25.30	63.50	28.58
10	26.97	31.75	31.00	68.10	31.75

Finish Code	Material & Finish
W	Aluminum Alloy, Cadmium Olive Drab
N	Aluminum Alloy/ Electroless Nickel
ZN	Aluminum Alloy/ Black Zinc Nickel

Band Lock EMI/RFI

BEL1	S	S	L	10	03	3	C	W	S
BASIC PART #	ANGLE	COUPLING	CONNECTOR GROUP	SHELL SIZE	ENTRY SIZE	STANDARD LENGTH & FIGURE	B:W/ Band X: W/O Band	MATERIAL & FINISH	SLOT
	S: Straight A: 90 B: 45	S: Self Lock	K: MIL-DTL-38999 Series I & II L: MIL-DTL-38999 Series III & IV	Table A	Table A			Table B	(Omit for none)

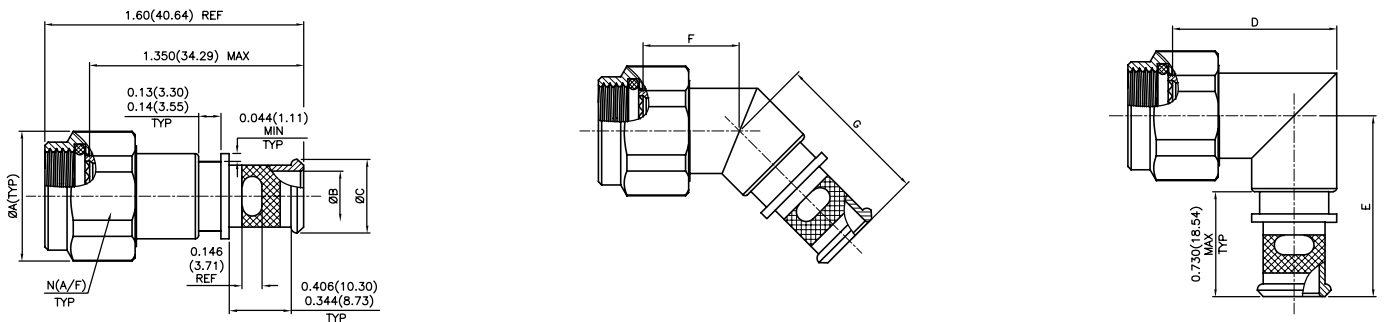

Shell Size	ØA MAX.		N HEX		B				C REF.				D MAX.	
	Inch	mm	Inch	mm	02		03		02		03		Inch	mm
					Inch	mm	Inch	mm	Inch	mm	Inch	mm		
8	0.803	20.40	0.668/ 0/686	16.99/17.42	-	-	0.250	6.40	--	--	0.395	10.0	1.375	34.93
10	0.858	21.79	0.736/ 0.750	18.69/ 19.05	-	-	0.312	7.90	--	--	0.457	11.60	1.437	36.50
12	0.984	24.99	0.860/ 0.875	21.84/ 22.23	0.312	7.90	0.438	11.10	0.457	11.60	0.583	14.80	1.562	39.67
14	1.157	29.39	0.980/ 1.000	24.89/ 25.40	0.438	11.10	0.562	14.30	0.583	14.80	0.707	18.00	1.687	42.85
16	1.280	32.51	1.100/ 1.125	25.58/ 27.94	0.500	12.70	0.625	15.90	0.645	16.40	0.770	19.60	1.750	44.45
18	1.406	35.71	1.224/ 1.250	31.09/ 31.75	0.625	15.90	0.750	19.10	0.770	19.60	0.895	22.70	1.875	47.63
20	1.516	38.51	1.348/ 1.375	34.24/ 34.93	0.625	15.90	0.812	20.60	0.770	19.60	0.957	24.30	1.938	49.23
22	1.642	41.51	1.469/ 1.500	37.31/ 38.10	0.688	17.50	0.938	23.80	0.829	21.10	1.083	27.50	2.062	52.37
24	1.768	44.91	1.581/ 1.625	40.16/ 41.28	0.750	19.10	1.000	25.40	0.895	22.70	1.145	29.10	2.125	53.98

Shell Size	E MAX.		F MAX.		G MAX.		S (No of Slots)	
	Inch	mm	Inch	mm	Inch	mm	Inch	mm
8	1.417	35.90	1.01	25.07	1.16	29.50	0.170	4.31
10	1.480	37.59	1.03	26.20	1.19	30.20	0.170	4.31
12	1.553	39.45	1.06	26.90	1.21	30.70	0.170	4.31
14	1.614	41.00	1.08	27.40	1.24	31.50	0.250	6.35
16	1.678	42.62	1.11	28.20	1.26	32.00	0.250	6.35
18	1.773	45.03	1.12	28.40	1.27	32.30	0.500	12.70
20	1.796	45.62	1.15	29.20	1.30	33.00	0.500	12.70
22	1.859	47.22	1.17	29.70	1.33	33.80	0.500	12.70
24	1.919	48.74	1.20	30.50	1.35	34.30	0.500	12.70

Finish Code	Material & Finish
W	Aluminum Alloy, Cadmium Olive Drab
N	Aluminum Alloy/ Electroless Nickel
ZN	Aluminum Alloy/ Black Zinc Nickel

Strain Relief EMI/RFI

BML1	S	S	K	10	W
BASIC PART #	ANGLE	COUPLING	CONNECTOR GROUP	SHELL SIZE	MATERIAL & FINISH
	S: Straight A: 90	S: Self Lock	K: MIL-DTL-38999 Series I & II L: MIL-DTL-38999 Series III & IV	Table A	Table A

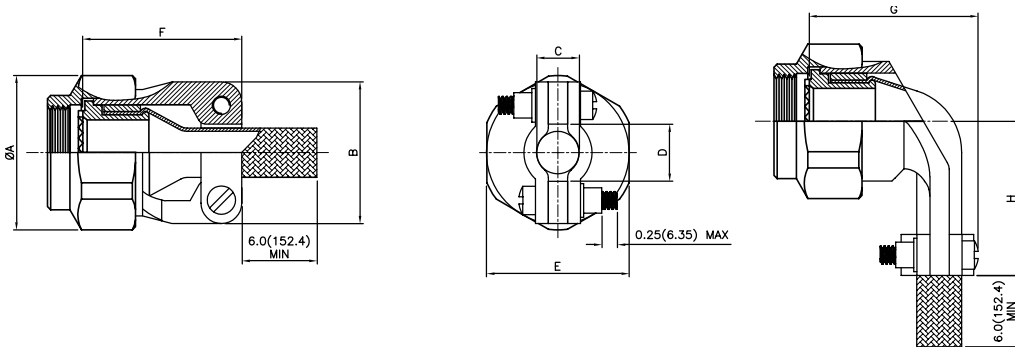

Size Number	ØA MAX.		B MAX.		C		D MIN.		E HEX.		F		G MAX.		H MAX.	
	Inch	mm	Inch	mm	0.031	0.78	Inch	mm	Inch	mm	Inch	mm	Inch	mm	Inch	mm
					Inch	mm										
8	0.858	21.79	0.880	22.40	0.219	5.60	0.220	5.60	0.750/0.736	19.05/18.69	0.780/0.939	19.81/23.85	1.128	28.65	0.940	23.88
10	0.984	24.99	0.940	23.90	0.264	6.70	0.270	6.90	0.875/0.860	22.23/21.84	0.860/1.059	21.84/26.90	1.168	29.67	1.000	25.40
12	1.157	29.39	1.120	28.40	0.344	8.70	0.350	8.90	1.000/0.980	25.40/24.89	0.950/1.199	24.10/30.45	1.248	31.70	1.120	27.69
14	1.280	32.51	1.190	30.20	0.435	11.05	0.470	11.90	1.125/1.100	28.58/27.94	0.950/1.199	24.13/30.45	1.368	34.75	1.190	30.23
16	1.406	35.71	1.440	36.60	0.540	13.72	0.550	14.00	1.250/1.224	31.75/31.09	1.080/1.329	27.43/33.75	1.448	36.78	1.370	34.89
18	1.516	38.51	1.560	39.60	0.620	15.75	0.620	15.70	1.438/1.407	36.52/35.73	1.140/1.509	28.90/38.33	1.528	38.61	1.440	36.58
20	1.642	41.51	1.690	42.90	0.695	17.65	0.700	17.80	1.500/1.469	38.10/37.31	1.200/1.609	30.50/40.87	1.648	41.86	1.560	39.67
22	1.768	44.91	1.750	44.50	0.770	19.56	0.780	19.80	1.625/1.581	41.28/40.16	1.330/1.759	33.80/44.68	1.688	42.88	1.690	42.85
24	1.890	48.01	1.880	47.80	0.820	20.83	0.850	21.60	1.750/1.690	44.45/42.93	1.450/1.859	36.80/47.22	1.758	44.65	1.810	46.02

Finish Code	Material & Finish
W	Aluminum Alloy. Cadmium Olive Drab
N	Aluminum Alloy/ Electroless Nickel
ZN	Aluminum Alloy/ Black Zinc Nickel

Vibration Test Graphs

DUT: Backshell
 Serial Number: BML1SSK10W (3nos) OX Axis
 Project File Name: Random vibration 43.92grms.prj
 Profile Name: Default
 Test Type: Random
 Run Folder: .\RunFolder Apr 01, 2015 13-43-56
 Level: 100 %
 Control RMS: 44.258648 gn
 Full Level Elapsed Time: 08:00:00
 Lines: 400 Frame Time: 0.200000 Seconds
 Demand RMS: 43.941341 gn
 Remaining Time:00:00:00
 DOF: 154 dF:5.000000 Hz
 Data saved at 09:54:53 PM, Wednesday, April 01, 2015 Report created at 09:54:54 PM Wednesday, April 1, 2015

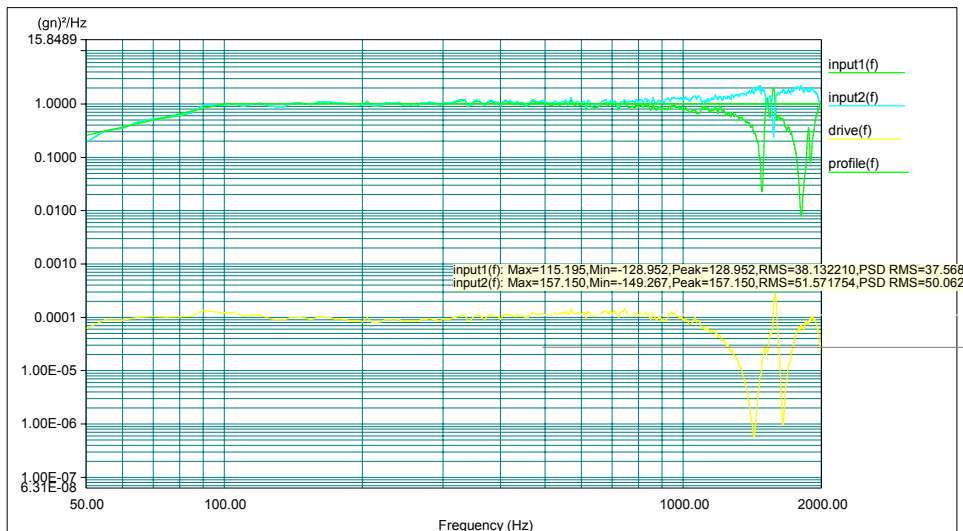
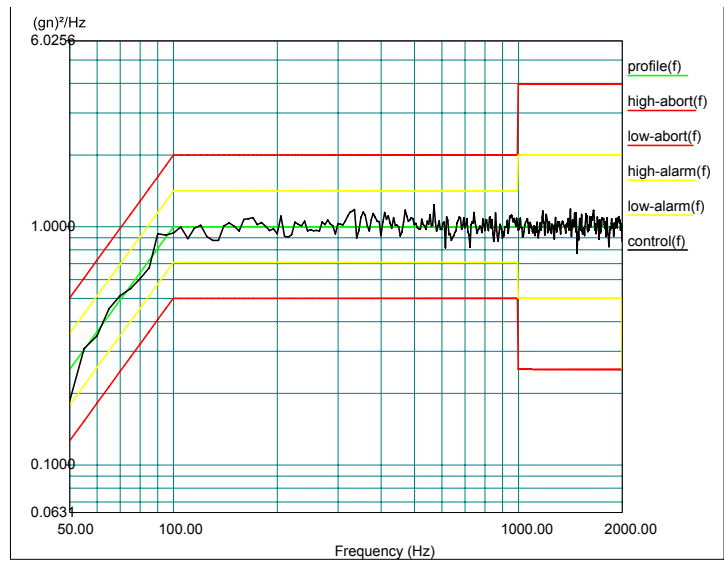
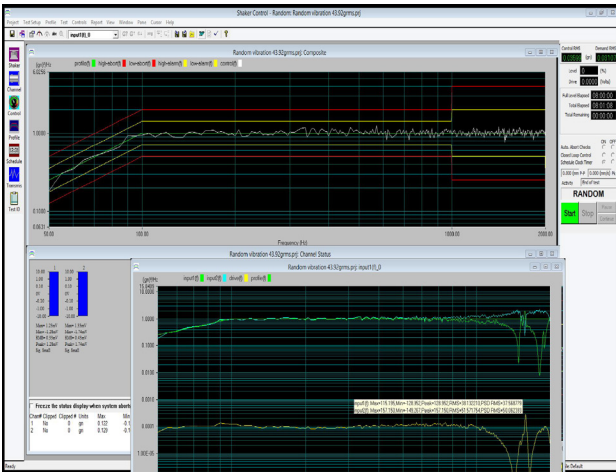

Vibration Test Graphs

DUT: Backshell

Serial Number: BML1SSK10W (3nos) OY Axis

Project File Name: Random vibration 43.92grms.prj

Profile Name: Default Test Type: \RunFolder Apr 02, 2015 09-29-13

Level: 100 %

Control RMS: 44.156834 gn

Full Level Elapsed Time: 08:00:00 Lines: 400 Frame Time: 0.200000 Seconds

Demand RMS: 43.941341 gn

Remaining Time:00:00:00

DOF: 154 dF:5.000000 Hz

Data saved at 06:57:43 PM, Thursday, April 02, 2015 Report created at 06:57:44 PM, Thursday, April 2, 2015

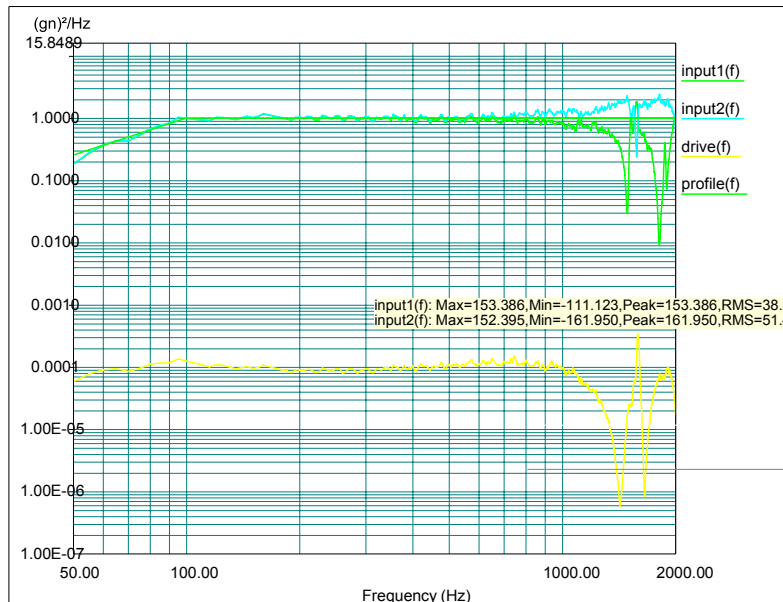
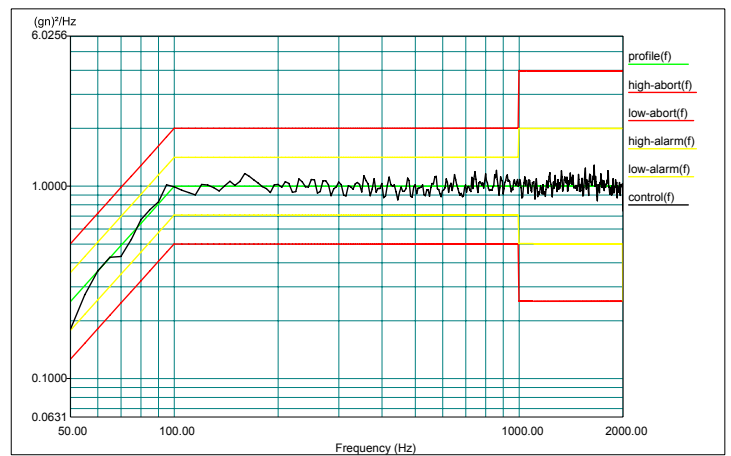
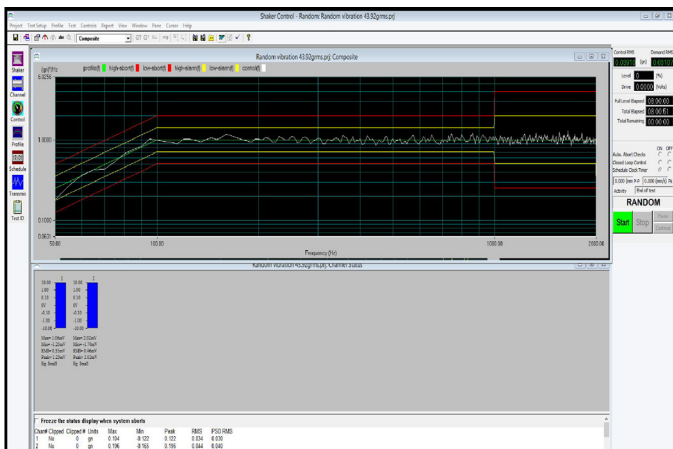

Vibration Test Graphs

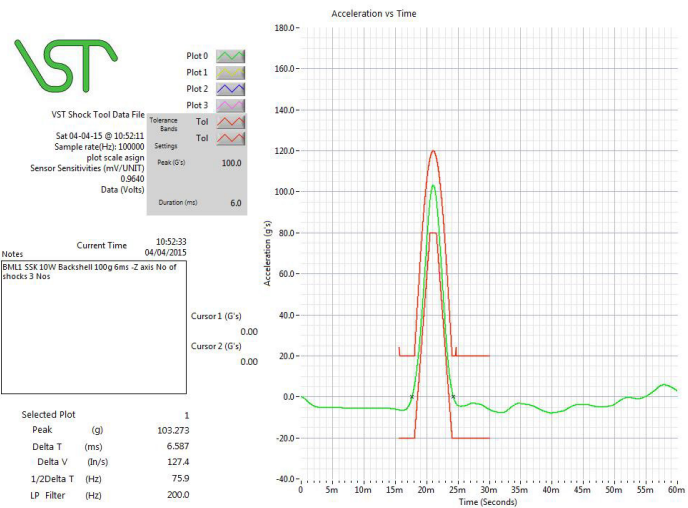
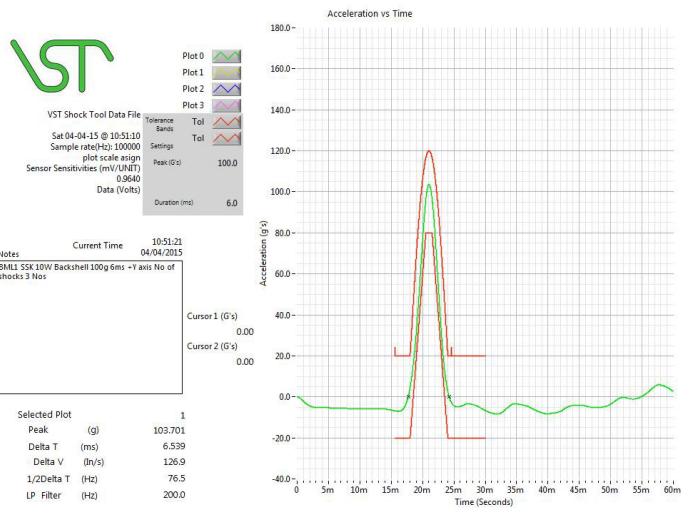
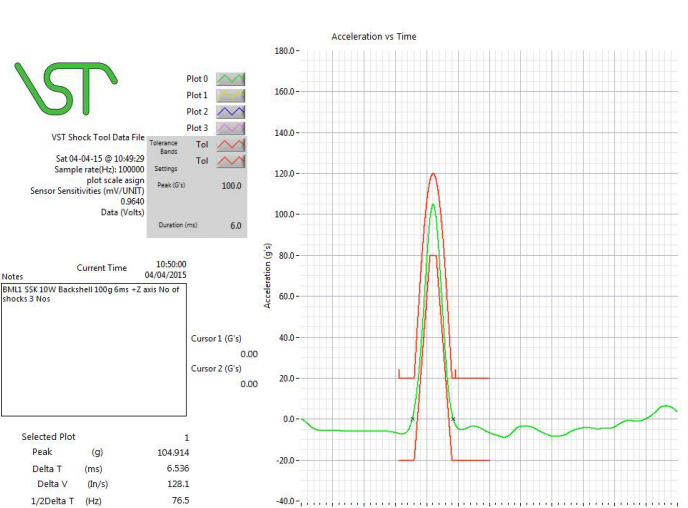
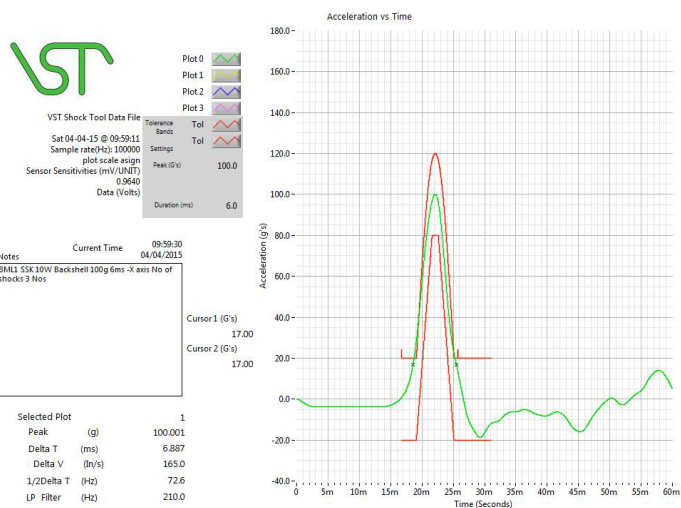
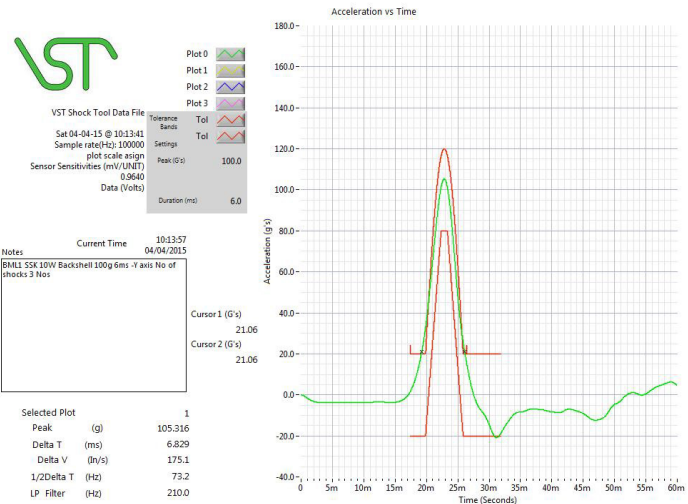
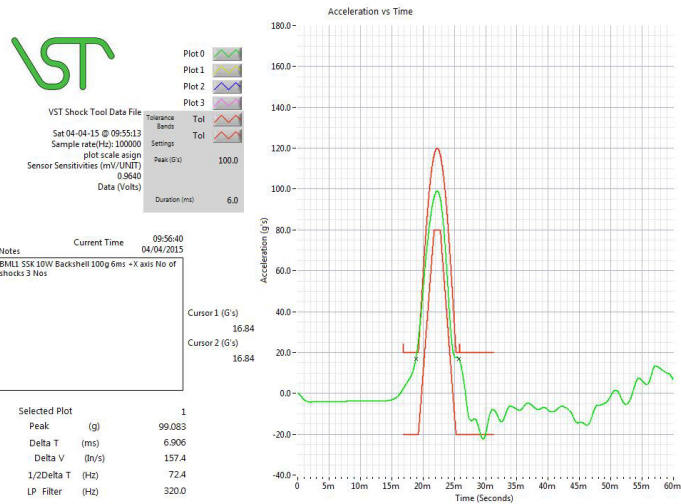

Amphenol Pcd
www.amphenolpcd.com

